

QTY.	PT. NO.	DESCRIPTION
------	---------	-------------

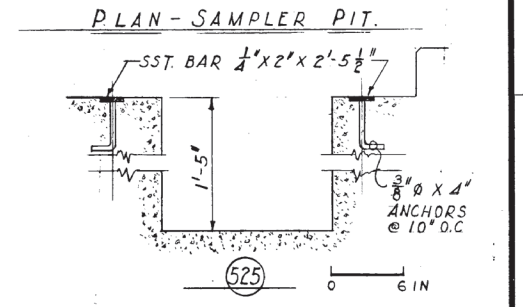
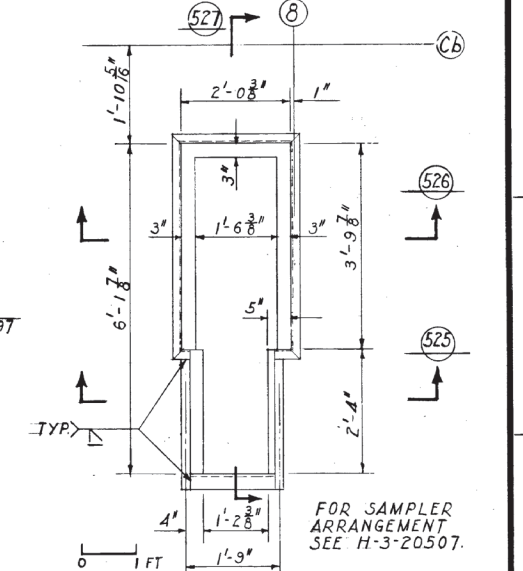
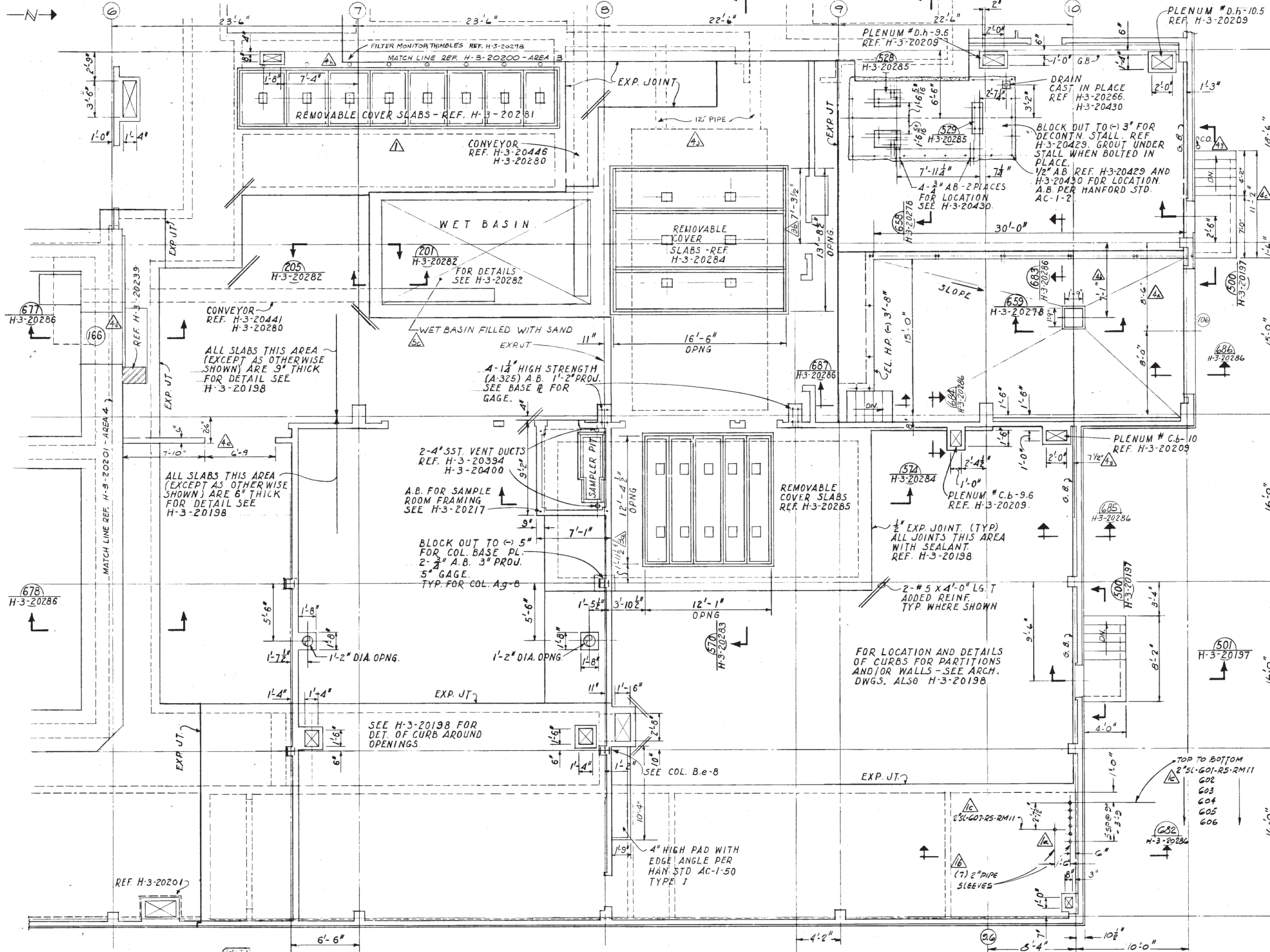

H-3-20202

NOTE
 PLATES 526 AND 529 TO BE CAST IN PLACE. TOP OF THESE PLATES SHALL BE FLUSH WITH BOTTOM OF FLOOR PLATE OF DECONT. STALL. REF. H-3-20429. NOTE THAT FLOOR SLOPES 1/8 IN. PER FT.

CHECKED BY: KOGER DATE: 1/10/68		APPROVED FOR CONST. BY: [Signature] DATE: 1/10/68		U. S. ATOMIC ENERGY COMMISSION HANFORD ATOMIC PRODUCTS OPERATION GENERAL ELECTRIC	
DRAWN BY: KOGER DATE: 1/10/68		APPROVED FOR PURCHASE BY: [Signature] DATE: 1/10/68		STRUCTURAL CONCRETE PLAN @ EL. 0'-0" AREA 5	
PRODUCT: AC-1-2 STD ANCHOR BOLTS DRAWING TITLE: H-3-20150 DWG LIST		PROJECT: 12.479 DRAWING NO.: H-3-20202		FUELS RECYCLE PILOT PLANT BLDG. NO.: 324 INDEX NO.: 0900	
REVISIONS: 5 DESCRIPTION: ADDED NOTE Z4-C PER SLEEVES FOR HANDRAIL DEL REV 1-4 b) REMOVED		REF. DRAWING: AC-1-2 DATE: 1/10/68		H-3-20202	

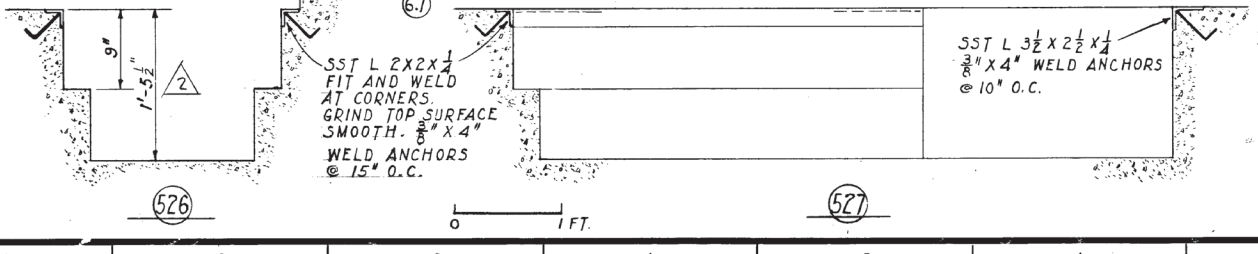

NO.	DESCRIPTION	REV.	BY	DATE	APPROVED BY	FOR	DATE
5	ADDED NOTE Z4-C PER SLEEVES FOR HANDRAIL DEL REV 1-4 b) REMOVED	1	PNL	1/10/68			